

SOA-L-OEC-1550 - 1.55 μ m Linear Semiconductor Optical Amplifier (SOA)

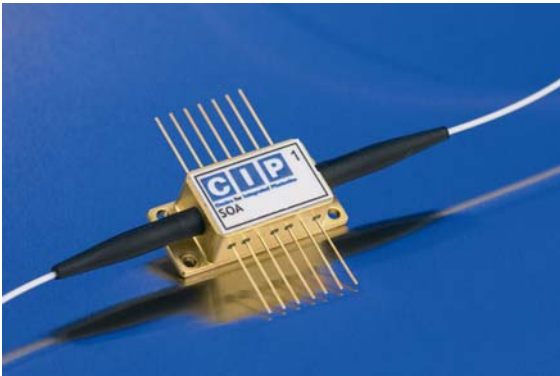

Features

- 1.55 μ m operation
- Very high saturated output power (>14dBm)
- Low noise figure (<7.5dB)
- Low ASE ripple (<0.2dB)
- Low polarisation dependence (1dB)
- InP buried heterostructure design
- TEC cooled
- Available as packaged device or chip-on-carrier
- APC connectors provided

Application Examples

- Power booster (DWDM & CWDM networks)
- Transmission amplifier
- OADM gain block
- Access PON amplifier

Description

The Linear SOA is a low confinement factor device optimised for moderate gain, low noise and high saturated output power. It utilises CIPs proprietary InP buried heterostructure design and is available in either a 14-pin butterfly package with a thermistor, thermo-electric cooler and single mode fibre pigtailed or as a custom chip-on-carrier product (including chip arrays).

Custom specification variants may be defined as appropriate in other custom wavebands. More detailed operation characteristics outside specification below are available on request.

Optical and electrical specifications All measurements are at 20°C & 1535-1560nm unless stated otherwise. I=bias current

Item	Test condition	Min.	Typ.	Max.	Unit
Gain	I = 500mA	10		16	dB
Polarisation Dependent Gain (PDG)	I = 500mA		1		dB
Noise Figure (NF)	I = 500mA		6.5	7.5	dB
Saturated Output Power (SOP)	I = 500mA	14			dBm
ASE Ripple	I = 500mA			0.2	dB

Absolute maximum ratings

Item	Symbol	Rating	Unit
Maximum DC current forward bias	I_{Fmax}	600	mA
Maximum DC voltage forward bias	V_{Fmax}	3.0	V
Maximum DC voltage reverse bias	V_{Rmax}	2.0	V
Maximum optical input power	P_{Max}	+13	dBm
Maximum TEC current	TEC_{IM}	2.0	A
Maximum TEC voltage	TEC_{VM}	3.6	V
Operating temperature	T	15-40	°C
Storage temperature	T_s	10-70	°C
Fibre type	SMF-28 900µm tight buffer, >1m		

Ordering Information— Part Number SOA-L-OEC-1550

For chip on carrier, or custom products please contact CIP Sales on +44 1473 663210 or e-mail sales@ciphotonics.com. For details of your local agent, visit www.ciphotonics.com

Wiring Diagram and Dimensions

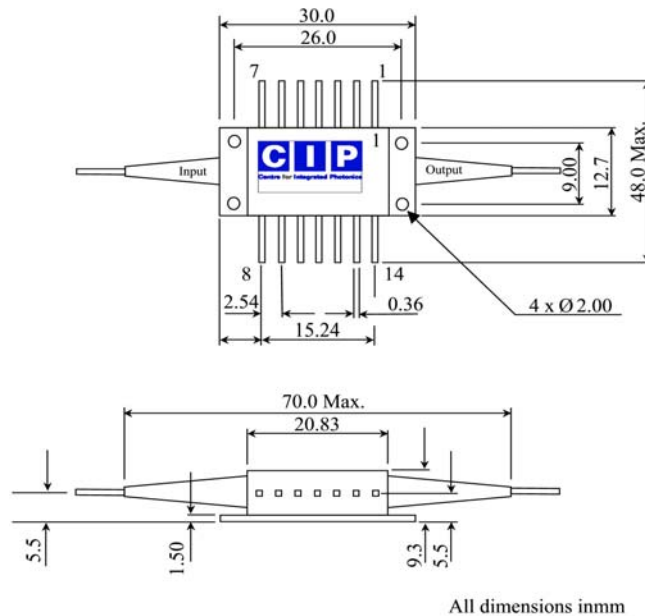

Pin Number	Connection
1	Cooler (+)
2	Thermistor
3	Case Ground
4	NC
5	Thermistor(10kΩ)
6	Case Ground
7	NC
8	NC
9	NC
10	SOA Chip (+)
11	SOA Chip (-)
12	Case Ground
13	Case Ground
14	Cooler (-)

Device also available in a 7 pin / SMA style package

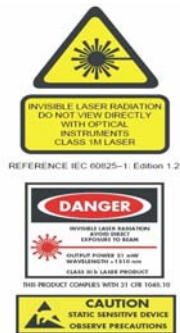

CIP reserves the right to make changes in the design, specifications and other information at any time, and without prior notice. The information contained within the Data Sheet is believed to be accurate. However, no responsibility is assumed for possible inaccuracy or omission. Any information contained herein shall legally bind CIP only if it is specifically incorporated in the terms and conditions of a sales agreement.

Parts of this product are manufactured under one or more of the following patents licensed from British Telecommunications PLC :

European 143000;384764;416879;531377;890129;156566;227783;218344;279680;261943;390614;174729;228435;228435;242084;245085;746887;767923;830721;1181591;93527.3;1183561;170457;225015;247834;292328;320305;537237;624257;647327;94905188.2;691044;772924;782713;822425;822426;813761;97900375.3;97908417.5;97908417.5;865124 US 4826295;5426312;5481397;5202897;6008926;4734387;4728628;4935936;4754459;4964134;5242857;53329542;4736164;4817207;4981814;5015964;844929;5852696;6188511;6625371;6571037;959329/09;4744619;4793690;4879761;4969704;4973122;4995100;5216237;5371820;5656507;6075625;6229945;6097512;5719974;5832011;5917636;5841928;5978400;6104852;6052213;5974073;6178280 Canada 297211;1284683;2182591;2193095;2221693;2372581;2372401;2373546;1255485;1244519;1281802;1296887;1293996;2085596;2117682;2280472;2153798;2155528;2185132;2199513;2367133;2212736;2240519;2248042;1268848;2047196;2065247;2082939;2243279;1236554;1228936;1261483;265604;1295722;1332341;2049356 Japan 2837265;2968335;1000942;2134710;2547001;2935415;2140794;2708165;2984365;2018663;1868104;2670519;2128400;2764141;1957418;2664457;2081567;3117708;3404040;3556665;3346570;95-525482;97-525789;97-534136

Parts of this product are manufactured under the following patent licensed from Corning Incorporated : US 10/376466