

## OPTIMIZING AMPLIFIER SPACING TO REDUCE TIMING JITTER IN 10 GB/S DM OPTICAL COMMUNICATION SYSTEM

Manjit Singh<sup>a</sup>, Ajay K. Sharma<sup>b</sup>, R. S. Kaler<sup>c</sup>

<sup>a</sup>Department of ECE, UCoE, Punjabi University, Patiala, Punjab. manjitsingh\_manjit@rediffmail.com

<sup>b</sup>Department of CSE, NIT (Deemed University), Jalandhar, Punjab, sharmaajayk@rediffmail.com

<sup>c</sup>Department of ECE, Thapar University, Patiala, Punjab.

**Abstract:** We present results for optimal EDFA amplifier spacing in optical RZ pulse for 10 Gbps dispersion managed optical communication system. The optical link length of the system is varied such that the second order chromatic dispersion remains compensated throughout the investigations taken. The idea is also simultaneously explored to find comparative performance in pre-, post- and symmetrical - dispersion compensation schemes of the system. The results obtained show strong relationship among duty cycle of RZ optical pulse, EDFA power, dispersion compensation scheme implemented. Moreover, it comments on chirp factor selection and extent of dispersion compensating fiber relationship.

### 1. INTRODUCTION

Non return-to-zero (NRZ) modulation format has been deployed in long-haul transmission systems [1], [2]. The format advantageously provides minimum optical bandwidth and minimum optical peak power per bit interval for given average power fiber and assumes that dispersion and nonlinearities are detrimental effects. However, with increased bit rates it has been shown that return-to-zero (RZ) modulation formats offer certain advantages over NRZ, as they tend to be more robust against distortions [3]. For instance, RZ modulation is more tolerant to non-optimized dispersion maps than NRZ schemes by the optimum balancing between fiber nonlinearities and dispersion is dependent on the pulse shape [4]. In fact, the best results of majority WDM transmission experiments regarding the distance-bit rate product have been achieved using RZ modulation formats in both terrestrial and transoceanic systems [4]. So, RZ data format with selected duty cycle could be important in improving the system performance.

Another problem in cascaded optical communication systems at higher data rates is timing jitter. Timing jitter expressions have been presented analytically using moment method with the assumption of a chirped Gaussian pulse in dispersion-managed (DM) light-wave systems [7]. The optimal choice of precompensation and postcompensation of a low-power system employing return-to-zero format (RZ) can minimize timing jitter along the fiber link [7-9]. It has also been shown that pulse distortions due to Kerr nonlinearity were significantly diminished by symmetrical ordering of the compensation sections [10]. It has been also demonstrated by using variational analysis that the noise-induced Gordon-Haus timing jitter in a

dispersion-managed soliton transmission system can be substantially reduced by appropriate placement of the amplifiers [11]. Thus RZ data format though widely studied but the simultaneous effect of duty cycle of RZ optical pulse, in line EDFAs (Erbium Doped Fiber Amplifiers) power and optimum amplifier spacing in dispersion managed optical system are required to be seen [1-11]. Such investigations would be useful to predict the longest length of the optical link under these selective parameters.

The authors have already presented an investigation on NRZ data format giving comparison of different dispersion compensation schemes [12]. Here, the study is further extended through this paper to find the optimum placement of amplifiers, duty cycle value and EDFAs power to have improved performance with RZ data format. In addition to these, three schemes of dispersion compensation with the use of dispersion compensating fibers are investigated. In Section 2, the optical simulated system and parameters are defined. In Section 3 comparison results are reported for these compensation methods and finally in Section 4, conclusions are drawn.

### 2. SYSTEM DESCRIPTION

The block diagram of the communication system used is shown in figure 1, whose optical link scheme is shown in the figure 2 for pre-dispersion compensation using standard and dispersion compensating fibers (DCFs). The main figure 1 shows transmitter section consists of data source, electrical driver, laser source and amplitude modulator. The data source produces pseudo random bit pattern at 10 Gb/s bit rate used to obtain statistical independence of results. The electrical driver

converts a logical input signal of a binary sequence (consisting zeros and ones) into an electrical signal and in desired data format. The duty cycle of RZ data format is adjusted in the investigation to study its comparative importance. The laser source generates laser beam at 1550 nm. Its output and the output of the electrical driver are given to a modulator.

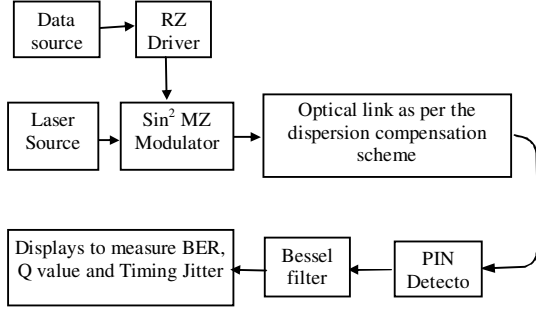

**Figure 1** Simulation model-I of optical communication system.

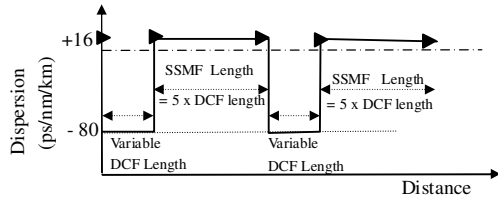

**Figure 2** Pre dispersion compensation map in the system-I (triangles indicate amplifiers after each fiber type). The position of DCF is exchange with SMF for post dispersion compensation while symmetric compensation used partial pre and partial post compensation scheme [13].

The output of modulator is fed to optical link through an EDFA acting as a booster amplifier. The optical link is defined as pre-, post- and symmetric compensations according to the order of spans placed. Two spans are considered so that there are two dispersion compensating fibers each -80 ps/nm/km dispersion and two standard single mode fibers each with 16 ps/nm/km dispersion. Their lengths are proportionately varied to have a dispersion managed system each time the investigations done as indicated in figure 2. The optical signal is amplified after both types of fibers with EDFAs for pre-compensation, post-compensation over one span so there are total of five EDFAs in the each link. In order to compare the two compensation configurations, we define equivalent symmetrical compensation configuration in the third case whereby the system is symmetrically compensated by two dispersion compensating fibers of negative dispersion against two standard fibers in between with EDFAs after each type of fiber. So there are five EDFAs for this configuration also. Length of optical link can be estimated through the

simple relation  $[= 2 \times (\text{Length of SSMF}) = 2 \times 5 \times (\text{length of DCF})]$  in each case. Thus, the link length can be varied indirectly by keeping different lengths of DCF fiber as shown in the figures from 3 to figure 5. The optical signal is detected at the receiver by PIN detector and is passed through electrical filter and the final output is observed on BER meter, Q meter to read corresponding values which are subsequently plotted.

### 3. RESULTS AND DISCUSSIONS

The second order chromatic dispersion of standard single mode fiber is compensated with dispersion compensating fibers in each of three compensation models considered. The relation  $D_1L_1 + D_2L_2 = 0$  may be used to verify compensation, where  $D_i$  and  $L_i$  are the first dispersion parameter and length of the respective single mode and dispersion compensating fibers. In our system,  $D_{DCF} = -80$  ps/nm/km,  $D_{SMF} = 16$  ps/nm/km and if  $L_{DCF} = x$ , then  $L_{SMF} = 5x$ . Thus considering DCF length variable, one can find proportionate SMF length. This idea will result in dispersion managed system at each value of DCF length considered which is used here in this paper also. The third order dispersion can cause dispersion to small extend and neglected in present discussion. For single channel light wave systems, the dominant nonlinear phenomenon that limits the system performance is self-phase modulation (SPM). If the launch power over the amplified link is satisfying the relation (1) of peak power then SPM due to phase accumulation over multiple amplifiers is of little concern [7].

$$P_m < 0.1\alpha / (\gamma N_A) \quad (1)$$

Where  $P_m$  (watts) is input peak power,  $\alpha$  (dB/km) is attenuation,  $\gamma$  ( $W^{-1}/km$ ) is nonlinear coefficient,  $N_A$  is number of amplifiers in link.

A generalized equation of pulse propagation called nonlinear Schrodinger equation (NLSE) with neglecting third order dispersion, has the form (2)

$$\frac{\partial A}{\partial z} + i\frac{\beta_2}{2}\frac{\partial^2 A}{\partial t^2} = -\frac{\alpha}{2}A + i\gamma|A|^2A \quad (2)$$

Where  $A(z, t)$  is slowly varying amplitude of pulse envelope,  $\beta_2$  is group velocity dispersion,  $\alpha$  is attenuation and  $\gamma$  is nonlinear coefficient related to SPM. Because of non linear nature of the equation (2), it is usually solved numerically. The calculation of the propagation in the optical fibers is performed by standard split-step algorithm with adaptive step-size [7]. Sequence lengths of 1024 bits are used to

decrease error less than  $\pm 1$  dB in the calculation of Q value and also to keep the corresponding error in BER and timing jitter under control.

In order to observe the dependence of duty cycle of RZ optical pulse on the output of the communication link, duty cycle values are varied from 0.2-0.8 in 0.2 step size. Five fixed-output gain EDFAs are used in link whose gains are changed simultaneously in the link to provide output power 8-12 dBm in steps of 2 dBm to observe the role of EDFAs. The all graphs drawn have horizontal plots indicating permissible limit of BER =  $10^{-9}$  and timing jitter = 16 ps to decide the system performance. The BER and duty cycle value at 8 dBm fixed-output power of EDFA gives indication that pre-dispersion compensation scheme is sharply affected by duty cycle and link length. It is assumed that system is only useful i.e. if BER <  $10^{-9}$ .

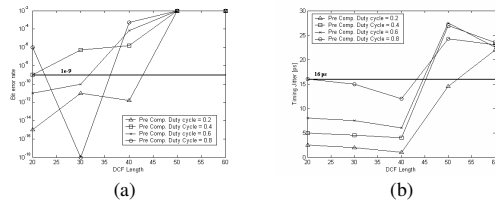

**Figure 3.** Performance of the Pre-dispersion compensated system at RZ pulse duty cycles values 0.2, 0.4, 0.6 and 0.8 when EDFA power = 10 dBm in terms of a) BER versus DCF length [km] b) Timing Jitter versus DCF length [km].

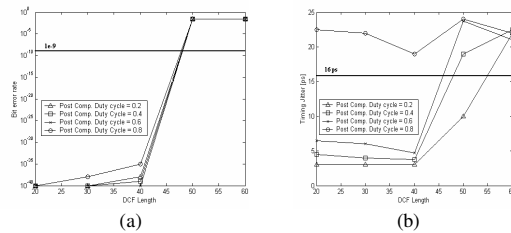

**Figure 4.** Performance of the Post-dispersion compensated system at RZ pulse duty cycles values 0.2, 0.4, 0.6 and 0.8 when EDFA power = 10 dBm in terms of a) BER versus DCF length [km] b) Timing Jitter versus DCF length [km].

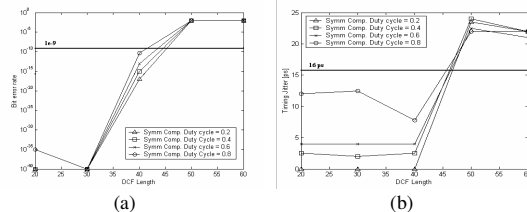

**Figure 5.** Performance of the Symmetrical-dispersion compensated system at RZ pulse duty cycles values 0.2, 0.4, 0.6 and 0.8 when EDFA power = 10 dBm in terms of a) BER versus DCF length [km] b) Timing Jitter versus DCF length [km].

For pre compensation if duty cycle is changed from 0.2-0.8, the corresponding total viable length computed is from 400 km to 450 km. Thus, pre-compensation scheme results into possible optical link length at respective duty cycle in round bracket

are 400 km (0.8), 420 km (0.6, 0.4), 450 km (0.2). Therefore maximum link length supported by pre compensation irrespective of duty cycle is 400 km as listed in table 1 [13].

The corresponding timing jitter variations indicated that timing jitter can be improved by selecting low value of duty cycle. The other two schemes post and symmetric dispersion compensation at EDFA power 8 dBm perform well for the range of duty cycle. The post compensation scheme gives small sensitivity to the duty cycle. Here, the smaller duty cycle value means smaller value of timing jitter. The result of symmetric compensation scheme at 8 dBm shows that the system gives less dependency on duty cycle also. This gives the optimum performance of system results into link length of 470 km and 400 km for post and symmetric dispersion compensation scheme respectively mentioned in table 1. After these maximum lengths mentioned, the system gives poor performance because of accumulation of nonlinearities SPM and ASE noise.

**Table 1** Maximum Link length considering all duty cycle cases.

Dispersion Compensation Schemes	Link length at EDFA power = 2 x 5 x DCF length (km)		
	8 dBm	10 dBm	12 dBm
Pre	400	200	Not Feasible
Post	470	470	470
Symmetric	400	420	370

Further the effect of EDFAs power is observed by keeping the same 10 dBm in the three schemes and its results are plotted in the graphs shown in the figure 3, 4 and 5. The pronounced effect of duty cycle is observed in pre compensation scheme. The minimum link length at a respective duty cycle in bracket is 20 km (0.6) while maximum value of link length is 42 km (0.2). These results are mentioned in the table 1 and its variation in figure 3 (a). As higher link length of 22 km is obtained, the low value of duty cycle will be advisable. In the figure 3(b), the corresponding timing jitter variations are shown. At 10 dBm EDFA power, results of figure 4-5 show that the post and symmetric compensation schemes show less sensitivity and provide guaranteed link length of 470 km (any), 420 km (0.8) in respective order [13].

In another model, the percentage of post compensation and chirp selection has been investigated to reduce timing jitter. It explored the wide range of chirp - 5, -3, -1, 0, 1, 3, 5 in addition to post compensation extent found in literature in this aspect. The control of accumulated timing jitter after the addition of each span (consisting of SMF and an amplifier) has been established by the respective choice of the modulator chirp. It happens because of

spectrum widening or compressing of optical pulse by chirping which reduces the timing jitter by appropriate chirp factor of modulator. So, the chirp value of external modulator should be set to either 0 or  $-1$  to reduce the timing jitter to reasonably low value but for large number of spans optimum performance may be achieved at other higher chirp (3 or 5) values leading smaller length of DCF.

#### 4. CONCLUSIONS

There is significant relationship among duty cycle value of RZ optical pulse, power level of in line fixed amplifiers, link length and dispersion compensation scheme to reduce timing jitter for the optical communication system. We have shown that pre compensation scheme performs better at EDFA power 8 dBm. The compensation scheme is highly sensitive to selection of duty cycle and EDFA power and link length varies widely in it. In the case of post compensation, we observe that the inter amplifier spacing less affected by the variations in EDFA power and duty cycle. The maximum link length of the system is obtained in post compensation scheme is 470 km and independent of five in line EDFAs power 8-12 dBm place after each fiber type. Alternatively, it gives maximum DCF length 47 km and SSMF 235 km at any duty cycle value except 0.8 among the considered values 0.2, 0.4, 0.6 and 0.8. The symmetrical compensation gives maximum link length 450 km with 0.2 duty at EDFA power 10 dBm but vary widely with duty cycle. We recommend that to achieve maximum link length the post dispersion compensation scheme, and small duty cycle value must be used being more resilient to the nonlinearity and timing jitter. It also makes our system more insensitive to the EDFA power fluctuations. For other It is concluded that the chirp value of external modulator should be set to either 0 or  $-1$  to reduce the timing jitter to reasonably low value but for large number of spans optimum performance may be achieved at other higher chirp (3 or 5) values leading smaller length of DCF.

#### REFERENCES

- [1] Trischitta P R et al, The TAT-12/13 cable network, *IEEE Commun. Magazine*, February 1996.
- [2] Barnett W C, The TPC-5 cable network, *IEEE Commun. Magazine*, February 1996.
- [3] Richter Andre, *Timing Jitter in Long-haul WDM Return-To-Zero Systems*, A Ph D Thesis, Berlin, February 2002.
- [4] Mohs G, Furst C, Geiger H, and Fischer G Advantages of nonlinear RZ over NRZ on 10 Gb/s single-span links, *Opt Fiber Commun Con.*, Baltimore, MD, paper FC2, 2000.
- [5] Sinkin O, Zweck J, Menyuk C, Effects of Nonlinearity-Induced Timing and Amplitude Jitter on the performance of Different Modulation Formats in WDM optical Fiber Communications Systems, *OFC 2003*.
- [6] Knudsen S N, *Electronics Letters*, **36** (2000), 2067-2068.
- [7] Agrawal G P, *Fiber-Optic Communication Systems*, John Wiley, 2002.
- [8] Agrawal G P, *Nonlinear-Optic Communication Systems*, John Wiley, 2002.
- [9] Santhanam J, Lakoba T I and Agrawal G P, Effects of precompensation and postcompensation on timing jitter in dispersion-managed systems, *Optics Letters*, **26** (2001), 1131-1133.
- [10] Breuer D, Kuppers F, Shapiro E G, Gabitov I and Turitsyn S K, Symmetrical dispersion compensation for standard monomode-fiber-based communication systems with large amplifier spacing, *Optics Letters*, **22**, (1997), 982-984.
- [11] Kutz J N and Wai P K A, Ideal amplifier spacing for reduction of Gordon-Haus jitter in dispersion-managed soliton Communications, *Electronics letters*, **34** (1998), 522-523.
- [12] Kaler R S, Sharma Ajay K, T S Kamal, Comparison of pre-, post- and symmetrical-dispersion compensation schemes for 10 Gb/s NRZ links using standard and dispersion compensated fibers, *Optics Communications*, (2002), 107-123.
- [13] Manjit Singh, Sharma Ajay K, Kaler R S, "Optimizing Amplifier Spacing in RZ Rectangular 10 GB/s DM Optical Communication System", *Optics Communications*, (2008), *in press*.